

JAMEX

uPVC WINDOWS & DOORS SYSTEMS

JAMEX
PREMIUM
SERIES

VILLA
PREMIUM
SERIES

MONORAIL
PREMIUM
SERIES



**FACTS
are
FACTS**

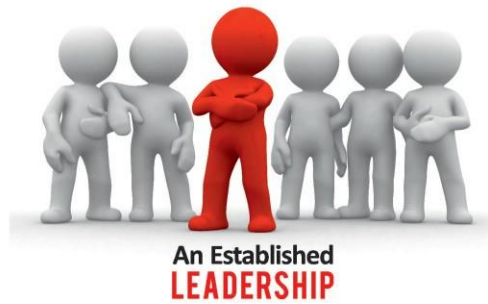

With this instrument you can
immediately check the credibility

JAMEX

uPVC WINDOWS & DOORS SYSTEMS

SPECIAL FEATURES:-

- GERMAN ENGINEERING
- PREMIUM FORMULATION WITH 6 PARTS OF TITANIUM DIOXIDE
- OUTER WALL THICKNESS AS PER 'B' CATEGORY OF 'IFT' ROSENHEIM, GERMANY (2.25MM. - 2.6MM.)
- LEAD FREE (CALCIUM ZINC FORMULATION)



JAMEX PREMIUM SERIES

- A UNIQUE DESIGN OF uPVC PROFILES

6 Types of Different Sliding Systems

- 60 mm. - 2 Track
- 74 mm. - Mono Rail
- 88 mm.
- 112 mm. - 3 Track
- 4 Track Sliding System - **Coming...**

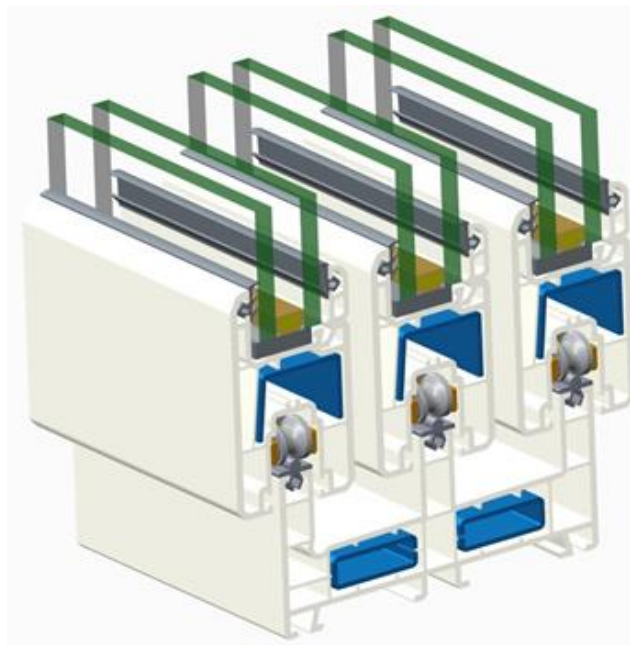

CASEMENT SYSTEM

60 mm. 3 chambers

The V-groove between the glazing bead and window sash gives a good appearance and is convenient for glass installation or disassembly.

20mm. groove secures the glass installation and provides a good heat preservation and noise insulation.

The 2.5mm. thickness three-cavity sash provides the optimized heat and energy preservation effect makes a perfect window.

The High UV formulation assures a smooth surface in nature luster and best anti-weathering effect.

The Hardware notches imported from Europe are especially suitable for various hardware fitting sourced from abroad; the location notch for DIMEX friction hinges is unparalleled.

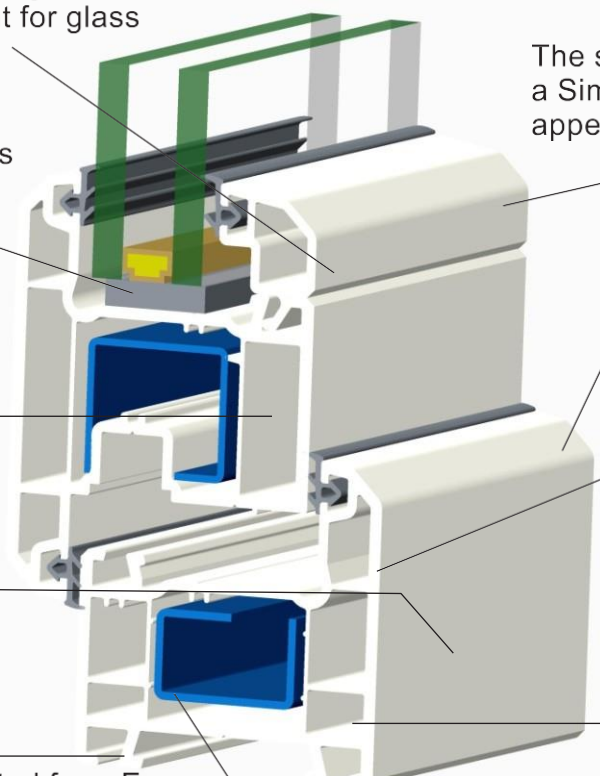

The streamlined Profile gives a Simple but graceful appearance.

The double-drainage assures that panel can be opened either inward or opened. An exclusive DIMEX design.

The 2.25mm. – 2.6mm. outer wall thickness three cavity profiles provides the optimized heat preservation and noise insulation effect. It beats the competition.

1.5mm. High quality galvanized steel improves the profiles strength.



Casement Inward
Opening
Windows Section



Casement Outward
Opening
Windows Section



Casement Outward
Opening
Door Section



Casement Inward
Opening
Door Section



2 Track Sliding
Windows Section



Edelweiss 88 Sliding
Window Series
Section



3 Track Sliding Door Section
with or without Aluminum
Low Threshold



3 Track Sliding Door
Section
Regular Threshold

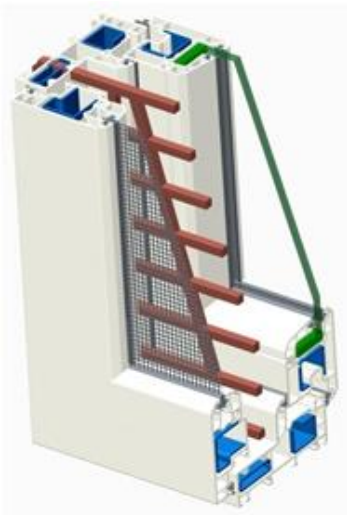

Double Rebate
(Double PATAM)
Villa Windows Section



Monorail Outer Frame
Section
Special Series for
Large Projects

We also supply Laminated Profiles in RENOLIT COLORS

- In Golden Oak
- Walnut
- Wenge
- Mahogany and others



CASEMENT WINDOWS & DOORS

60 Window Frame 410100

I:173253 e:35.38

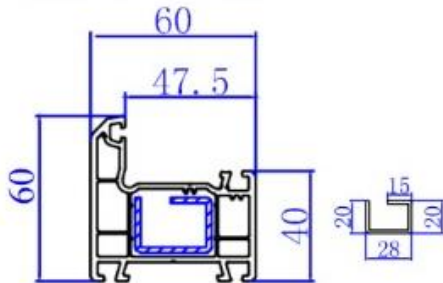

460100
t=1.5 Iy=1.312
t=2.0 Iy=1.665

60 Window Mullion 410400

I:238033 e:38

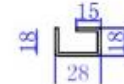
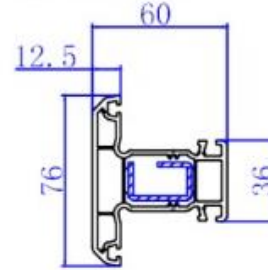

60400
t=1.5 Iy=1.201
t=2.0 Iy=1.522

60 Inward Window Sash 410200

I:254407 e:38.37

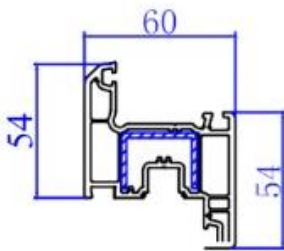

460200
t=1.5 Iy=1.553
t=2.0 Iy=1.986

60 Outward Window Sash 410300

I:291580 e:40.31

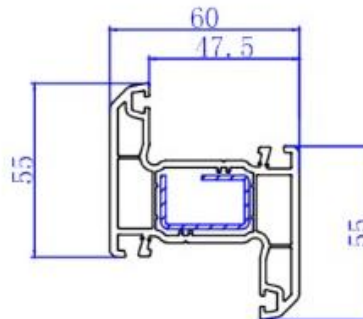
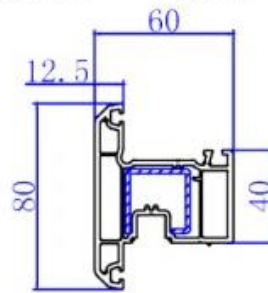

Movable Mullion 421600

67.8+03

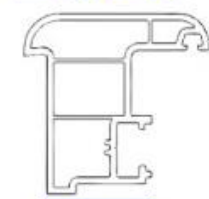

36+03



460300
t=1.5 Iy=1.740
t=2.0 Iy=2.213

60 Z Mullion 411200

I:223789 e:37.55

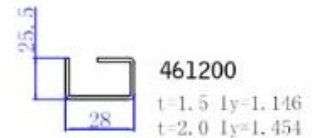

461200
t=1.5 Iy=1.146
t=2.0 Iy=1.454

60 Door Frame 410500

I:313519 e:40.23

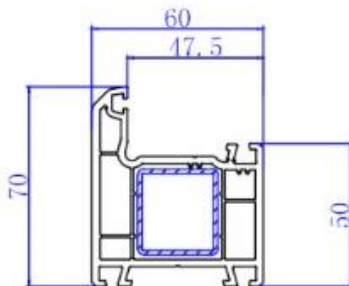

460500
t=1.5 Iy=1.913
t=2.0 Iy=2.433

60 Outward Door Sash 411300

I:909546 e:54.43

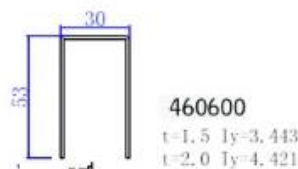
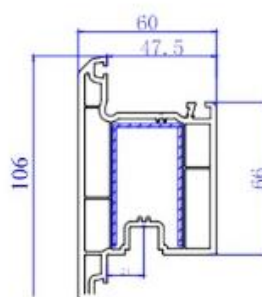

460600
t=1.5 Iy=3.443
t=2.0 Iy=4.421

60 Inward Door Sash 410600

I:909546 e:54.94

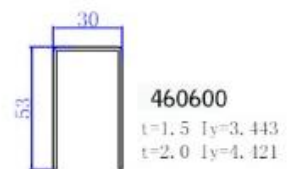
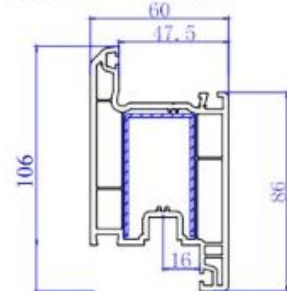

460600
t=1.5 Iy=3.443
t=2.0 Iy=4.421

SLIDING WINDOWS WITH OR WITHOUT MESH

62 Double Track Sliding Frame 410800

I:163555 e:27.74

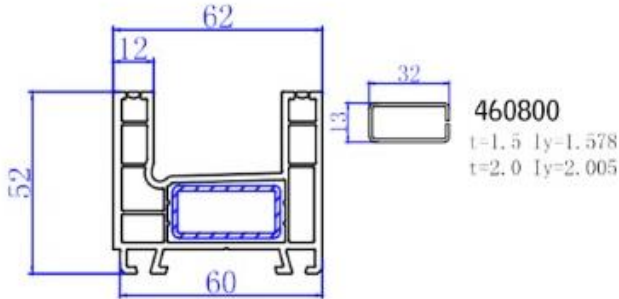

88 Triple Track Sliding Frame 410900

I:217051 e:27.2

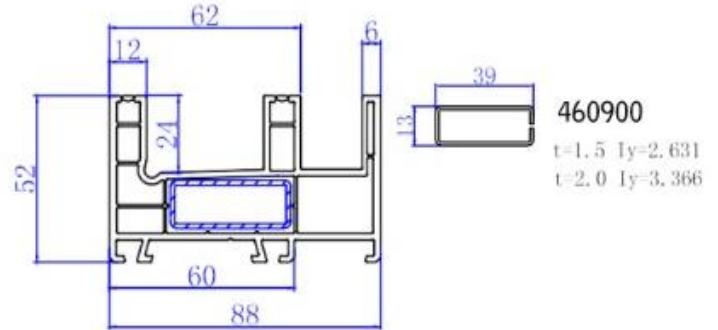

88 Cover Profile 420700

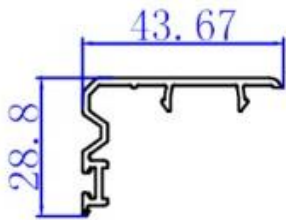

88 Sliding Mullion 411700

I:84048 e:30.00

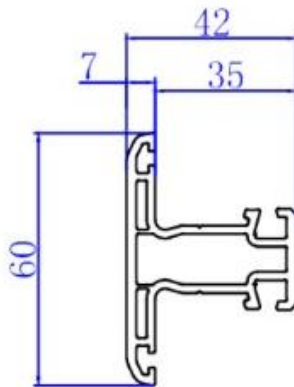

88 Fixed Frame 411500

I:134315 e:31.86

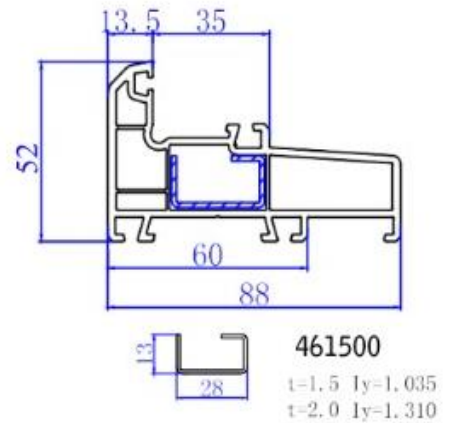

88 Sliding Sash 411000

I:227228 e:39.7

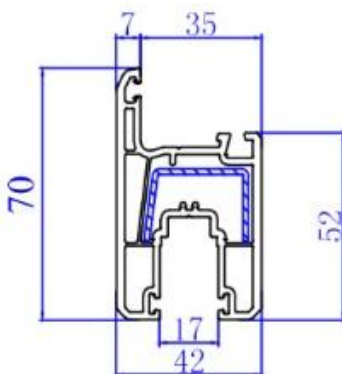

88 Mosquito Sash Mullion 421700

New Ad on

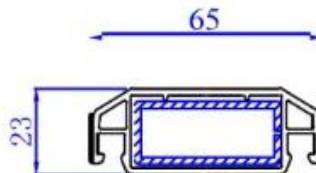

88 Mosquito Sash 421900

New Ad on

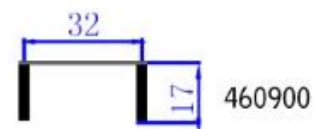
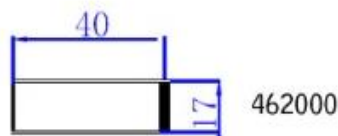
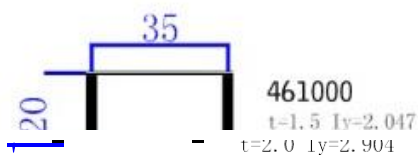
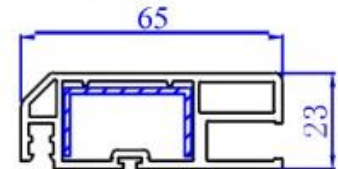

112 Sliding Frame 411800

I:215272 e:27.41

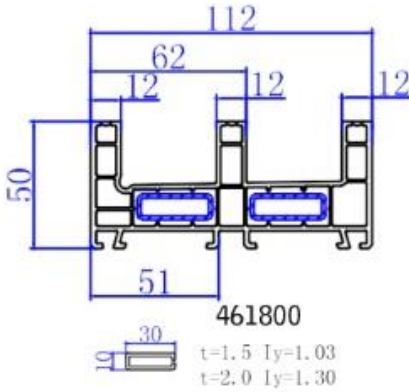

Sliding Door Sash 411900

I:425585 e:48.07

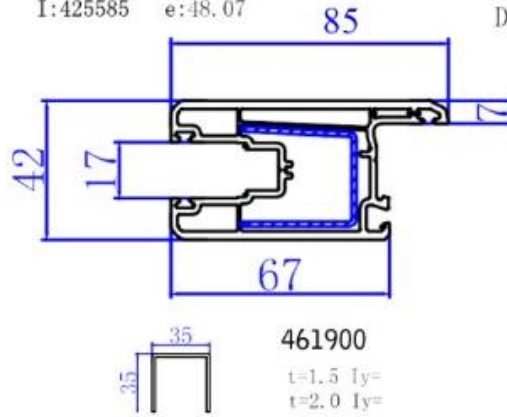

Cover Profile for Sliding Door 421100

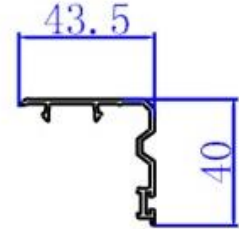

Glazing Bead 19.5 420100

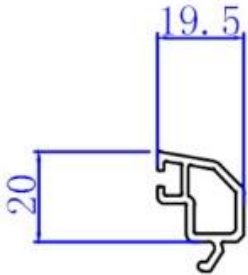

Glazing Bead 34.5 420200

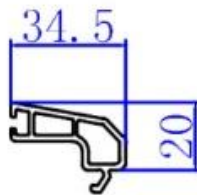

Glazing Bead 22 421200

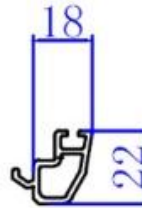

Glazing Bead 7 420300

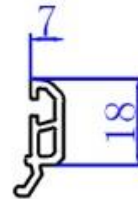

Dimex E88 Coupling Profile

88 Bar 420600

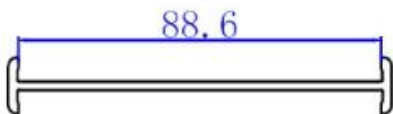

88 Square Post 420800

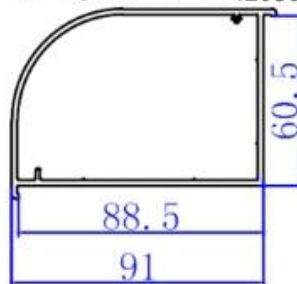

60 Square Post 420500

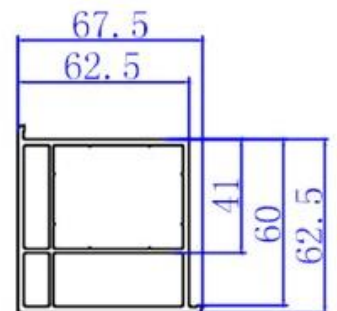

60 Bar 420200

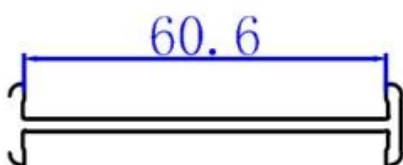

Interseal 421000

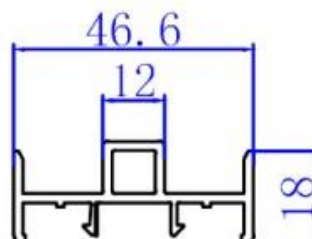

Hurricane Bar

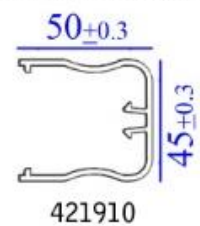

VILLA WINDOWS PROFILES

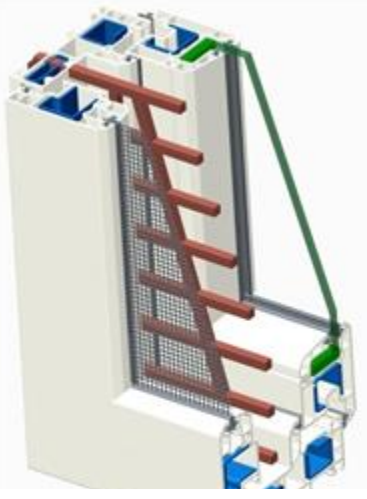

Villa Window Mosquito Sash 430020

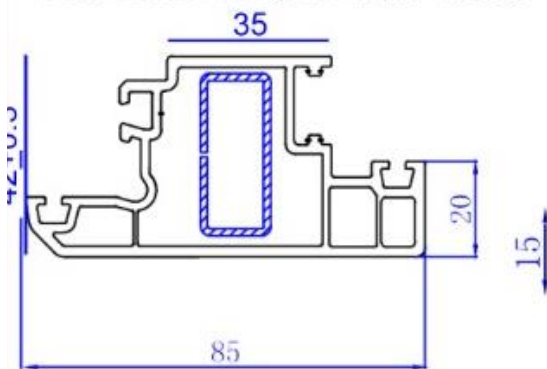

430010
Villa Window Outer

667900

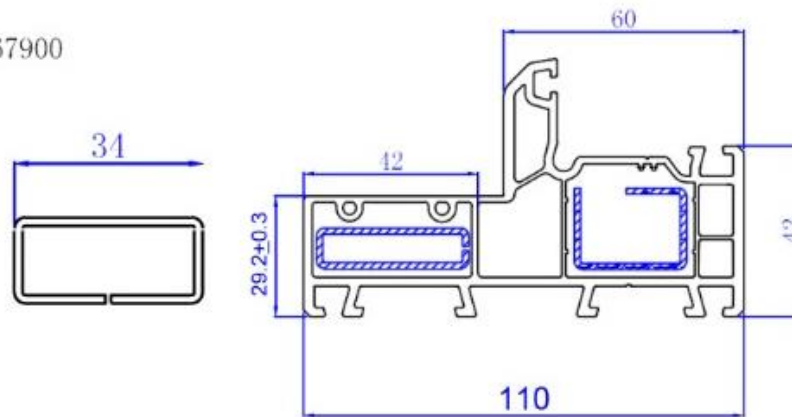

60 Outward Window Sash 410300

I:291580 e:40.31

(667800)

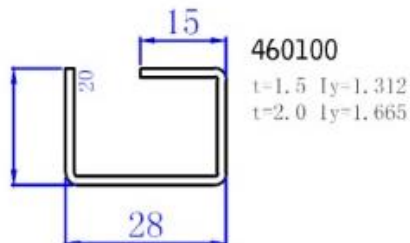
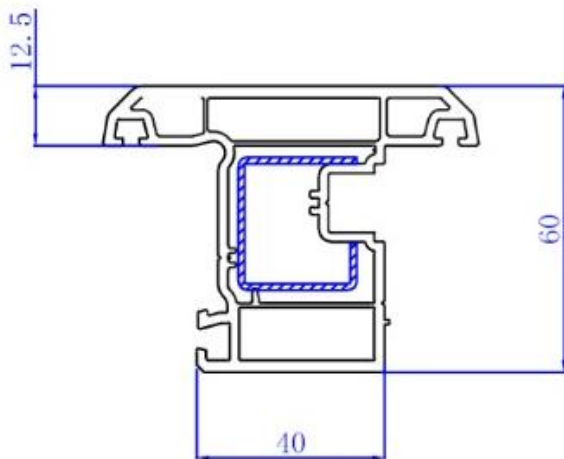

Glazing Bead 34.5
420400

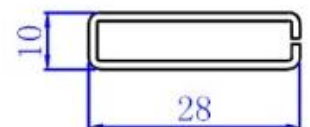

Glazing Bead 19.
420100

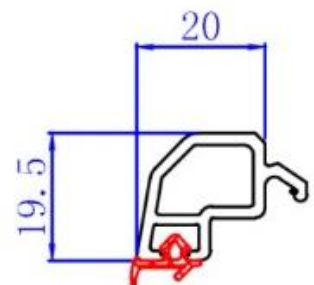
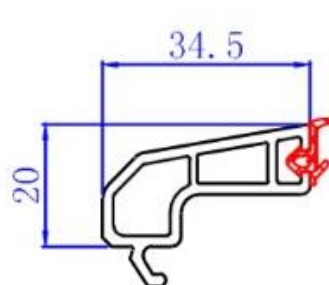
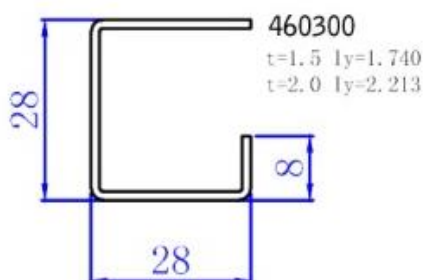

Mono Rail Outer 412200

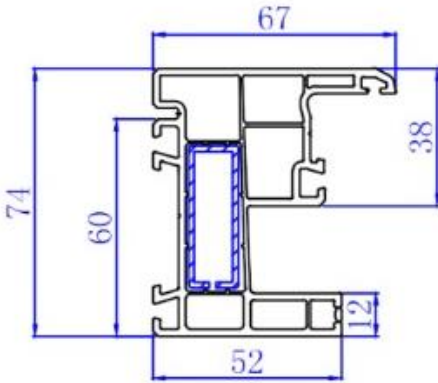

Glazing Bead 19.5
420100

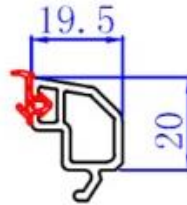

Glazing Bead 22
421200

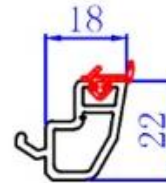

Glazing Bead 7
420300

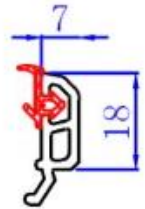

Mono Rail Mullion 412400

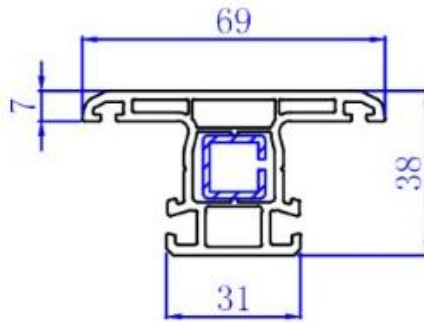

88 Sliding Sash 411000

I:227228 e:39.7

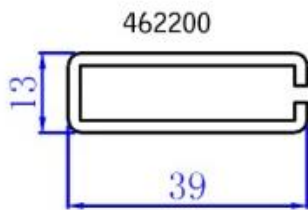
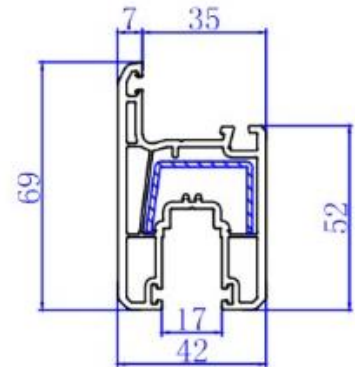

Sliding Door Sash 411900

I:425585 e:48.07

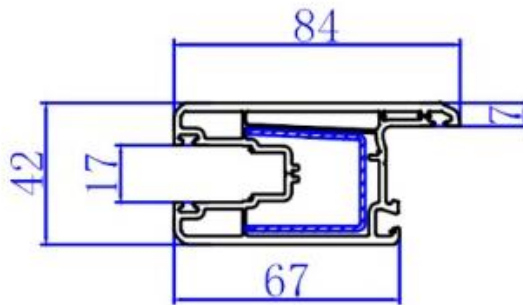

Cover Profile 420700

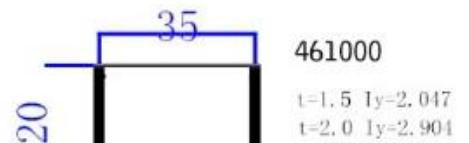
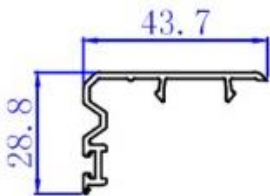

461000

t=1.5 ly=2.047
t=2.0 ly=2.901

Cover Profile 421100

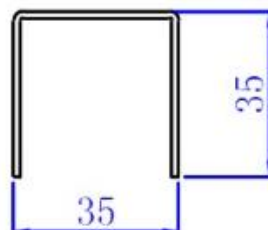
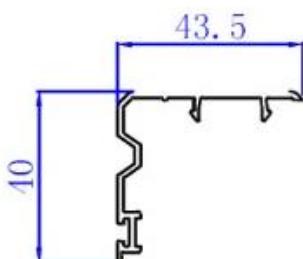

461900

t=1.5 ly=
t=2.0 ly=

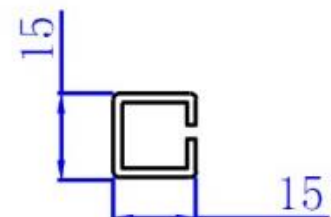



Quality Certificate

**25 Years Warranty for Laminated Profiles
10 Years Warranty for White Profiles.**

Jamex hereby warranty its supplied White Profiles for a period of 10 years, against all manufacturing and material defects.

- Jamex Profiles are anti UV & it Contains upto 6 parts Titanium Dioxide.
- Jamex Profiles are tested for RHOS, are Lead Free. – Jamex Profiles Outer Wall Thickness is upto 2.5mm. It belongs to B category of German IFT Classification as recommended for Hot Countries.
- Jamex Renolit Laminated profiles are warranted for 25 years/ Renolit original warranty shall be transferred to the customers.



Signature

www.jamexupvc.com



Corporate Office:

Rocket Ground, 14-1-430/11/1,
F.No. 501, 5th, Aghapura,
Hyderabad,
Telangana – 500001

Factory:

DHENUINDUSTRIESLLP
SY No. 98, Tulekalan (V),
Ibahimpatnam (V)
R.R. Dist. Telangana

Manoj Agarwal

Contact - +91-9849494542