



SYSTEMS OVERVIEW

Estd. 1933



German uPVC Windows & Doors System

WWW.DIMEXINDIA.COM





THIS DOCUMENT USER INFORMATION : This is a technical document for business discussions and use by Brand Dimex India representatives with their prospective clients and fabricators. Any misuse or reproduction of designs and information contained herein in essence or concept by third parties or other users without the knowledge of Dimex India Pvt. Ltd. is liable for legal action by Dimex India Private Limited.

**GERMAN ENGINEERING &
DESIGN BROUGHT TO
INDIA FOR YOU !**

**PREMIUM FORMULATION
WITH 8 PARTS OF
TITANIUM DIOXIDE**

**OUTER WALL THICKNESS
AS PER 'B' CATEGORY OF
'IFT' ROSENHEIM,
GERMANY [2.25MM - 2.6MM]**

**LEAD FREE [CALCIUM ZINC
FORMULATION]**



**A TRUSTED NAME
IN THE DOORS &
WINDOWS
PROFILES
SEGMENT SINCE
THE ONSET OF
uPVC IN INDIA**

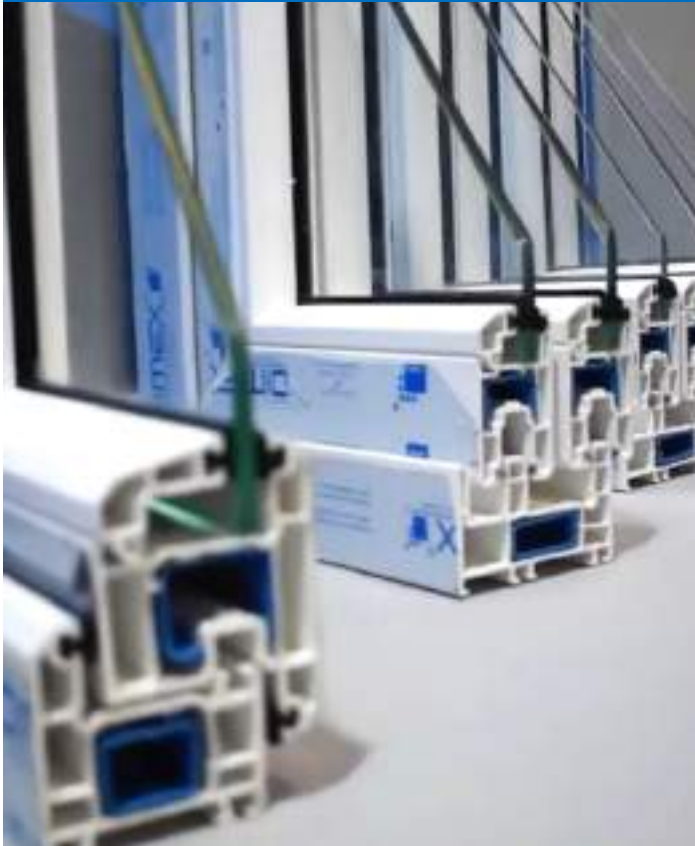

**HELPING YOU
LIVE SAFE
LIVE SECURE
SINCE 1933**

Estd. 1933

DIMEX[®]

German uPVC Windows & Doors System

A LEGACY BRAND

EDELWEISS

OUR PREMIUM SERIES



5 SLIDING SYSTEMS

- 60 mm 2 Track
- 74 mm Monorail
- 88 mm
- 112 mm 3 Track
- 4 Track Sliding System

CASEMENT SYSTEM 60 MM 3 CHAMBERS

- 1** V-Groove between the glazing bead & window sash has aesthetic appeal & is convenient for glass installation or disassembly
- 2** 20 mm groove secures glass installation and provides energy efficiency by containing loss of heat and cooling plus acoustic insulation
- 3** 2.3 mm wall thickness three-cavity sash makes the profile durable and further add to energy preservation and acoustic insulation
- 4** Dimex location notches for friction hinges are unparallelled. Our hardware notches are imported from Europe and are compatible with hardware sourced from anywhere
- 5** 15 mm high quality galvanised steel reinforcement improves the strength and longevity of the profile and the final finished product upon installation
- 6** High UV formulation assures smooth surface, best anti-weathering effect, minimal static deposition & makes it easy to maintain
- 7** Simple, streamlined and aesthetically engineered to compliment and enhance any facility design sensibility



**CASEMENT
INWARD OPENING
WINDOWS SECTION**



**CASEMENT
OUTWARD OPENING
WINDOWS SECTION**



**CASEMENT
OUTWARD OPENING
DOOR SECTION**



**CASEMENT
INWARD OPENING
DOOR SECTION**



**2 TRACK SLIDING
WINDOWS SECTION**



**EDELWEISS 88
SLIDING WINDOW
SERIES SECTION**



**3 TRACK SLIDING DOOR
SECTION WITH OR
WITHOUT ALUMINIUM
LOW THRESHOLD**



**3 TRACK SLIDING
DOOR SECTION
REGULAR THRESHOLD**



**DOUBLE REBATE (DOUBLE
PATAM) VILLA WINDOWS
SECTION**



**MONORAIL OUTER FRAME
SECTION
SPECIAL SERIES FOR
LARGE PROJECTS**



**GOLDEN OAK | WALNUT
WENGE | MAHOGANY
ANTHRACITE GREY | SATIN BLACK**

60 WINDOW FRAME 310100

I: 173253 e: 35.38

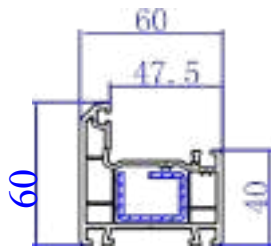

360100

t=1.5 ly=1.312
t=2.0 ly=1.665

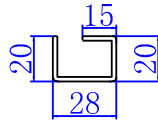

60 WINDOW MULLION 310400

I: 238033 e: 38

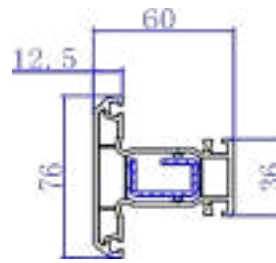

360400

t=1.5 ly=1.201
t=2.0 ly=1.522

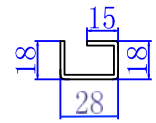

60 INWARD SASH 310200

I: 254407 e: 358.37

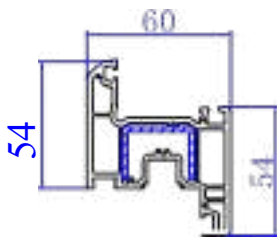

360200

t=1.5 ly=1.553
t=2.0 ly=986

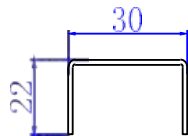

60 OUTWARD SASH 310300

I: 291580 e: 40.31

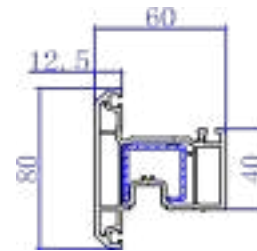

360300

t=1.5 ly=1.740
t=2.0 ly=2.213

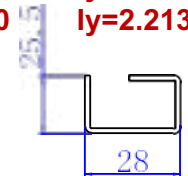

CASEMENT COMPACT FRAME 310110

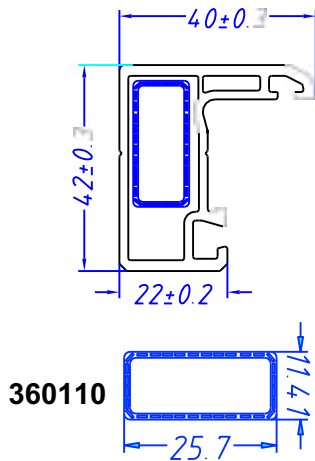

360110

60 Z MULLION 311200

I: 223789 e: 37.5

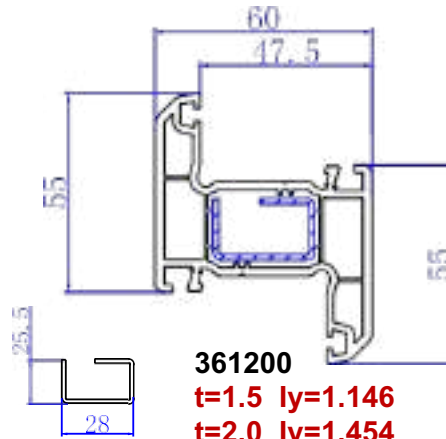

361200

t=1.5 ly=1.146
t=2.0 ly=1.454

MOVABLE MULLION 321600

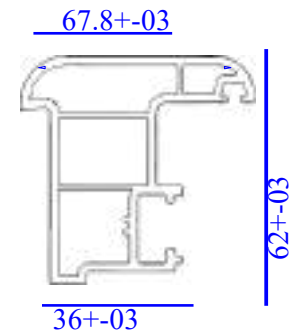

60 DOOR FRAME 310500

I: 313519 e: 40.23

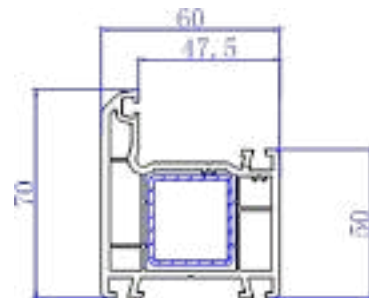

60 INWARD DOOR SASH 310600

I: 909546 e: 54.94

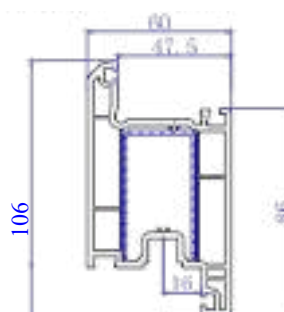

60 OUTWARD DOOR SASH 311300

I: 909546 e: 54.94

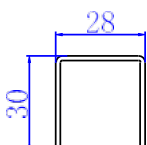
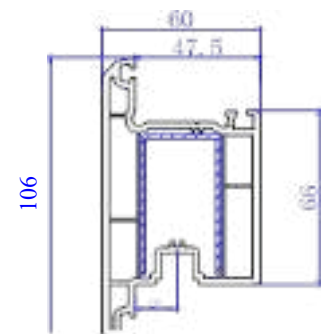

360500

t=1.5 ly=1.913
t=2.0 ly=2.433

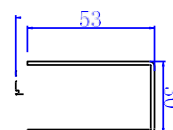

360600

t=1.5 ly=3.443
t=2.0 ly=4.421

62 DOUBLE TRACK SLIDING FRAME 310800

I: 163555 e: 27.74

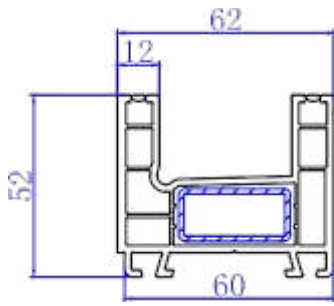

360800
t=1.5 ly=1.578
t=2.0 ly=2.005

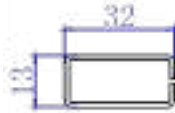

88 TRIPLE TRACK SLIDING FRAME 310900

I: 217051 e: 27.2

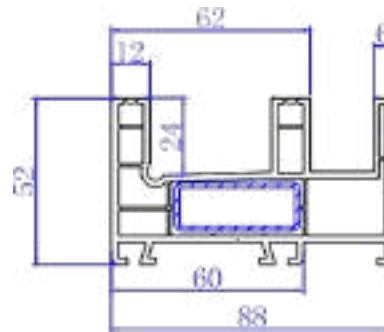

360900
t=1.5 ly=2.631
t=2.0 ly=3.366

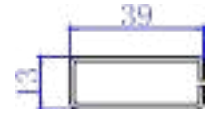

88 FIXED FRAME 311500

I: 134315 e: 31.86

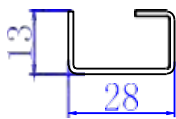
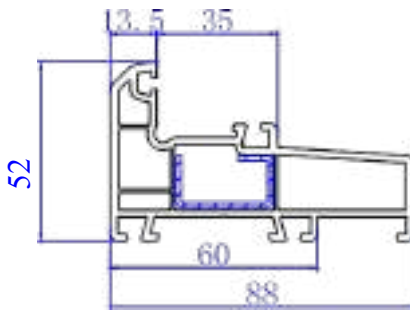

361500
t=1.5 ly=1.035
t=2.0 ly=1.310

88 SLIDING SASH 311000

I: 227228 e: 39.7

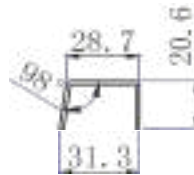
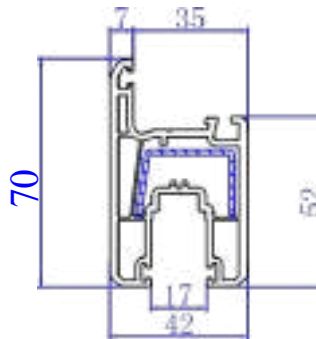

361000
t=1.5 ly=2.047
t=2.0 ly=2.904

COVER PROFILE 320700

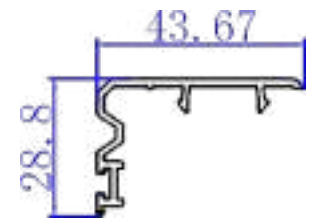

88 SLIDING MULLION 311700

I: 84048 e: 30.00

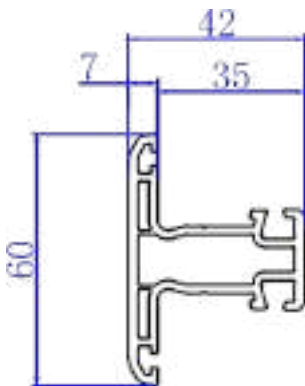

88 MOSQUITO SASH MULLION 321700

I: 321700

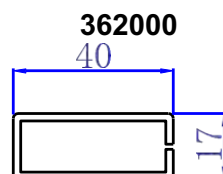
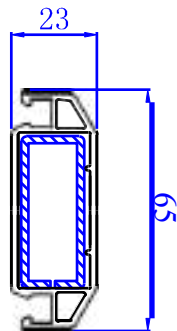

362000

88 MOSQUITO SASH 321900

I: 321900

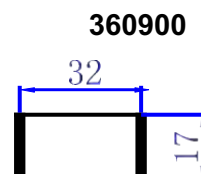
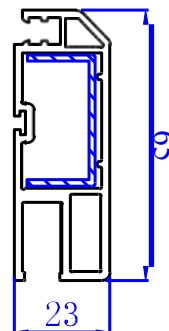

360900

MONORAIL 312200

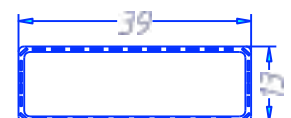
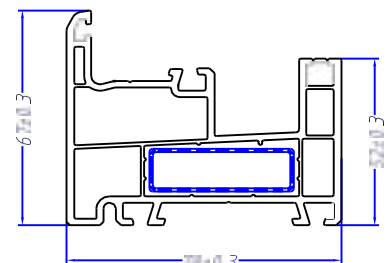

112 SLIDING FRAME 311800
l: 215272 e: 27.41

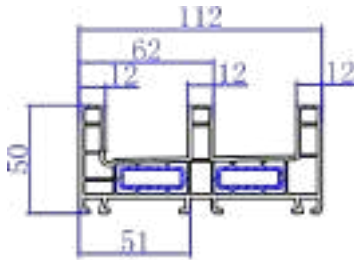

361800
t=1.5 ly=1.03
t=2.0 ly=1.30



SLIDING DOOR SASH 311900
l: 425585 e: 48.07

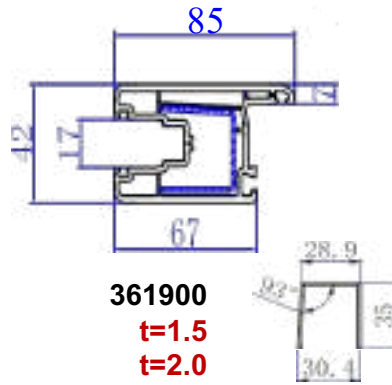

361900
t=1.5
t=2.0

COVER PROFILE FOR SLIDING DOOR 321100

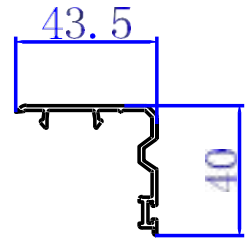

MONORAIL MULLION 312400

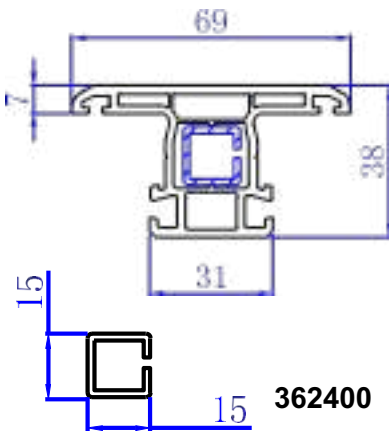

362400

60 SQUARE POST 320500

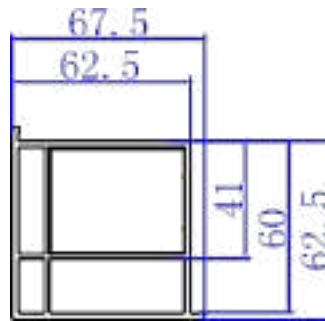

88 SQUARE POST 320800

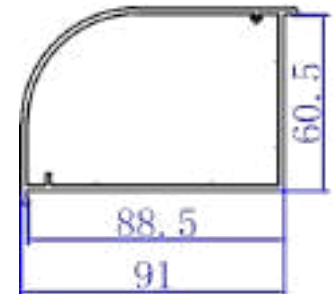

60 BAR 320200

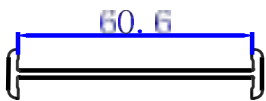

88 BAR 320600

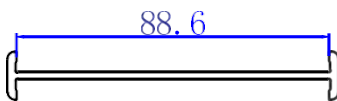

INTERSEAL 321000

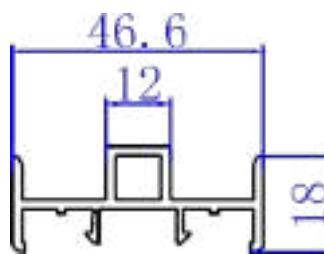

HURRICANE BAR 321910

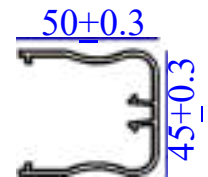

GLAZING BEAD 34.5 320400

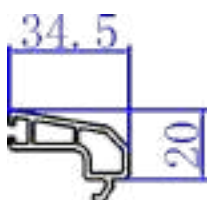

GLAZING BEAD 22 321200

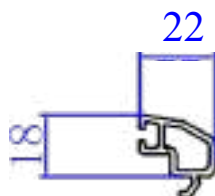

GLAZING BEAD 7 320300

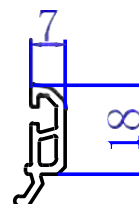

GLAZING BEAD 19.5 320100

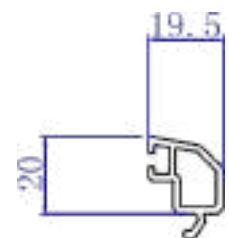

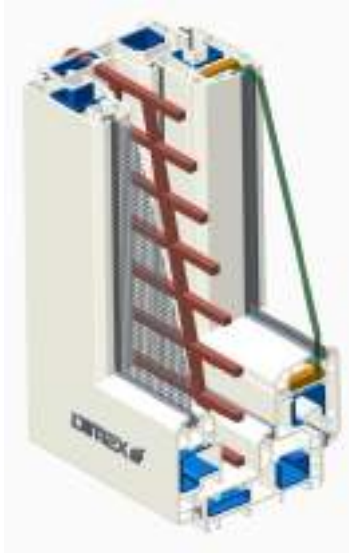

VILLA WINDOW OUTER 330010

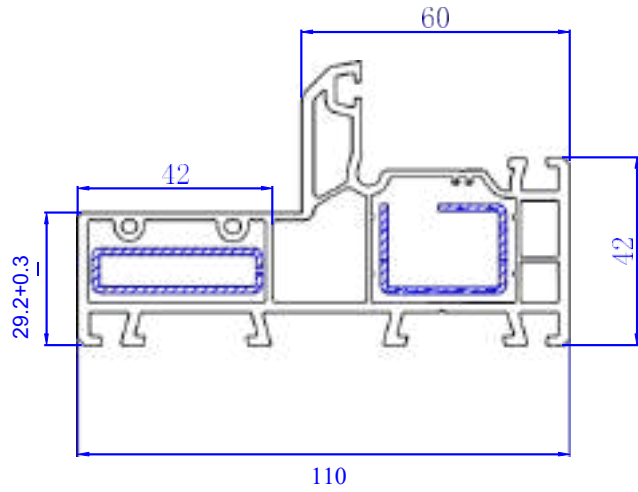

667800



360100

t=1.5 ly=1.312
t=2.0 ly=1.665

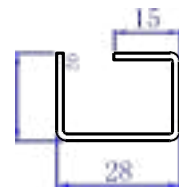

VILLA WINDOW MOSQUITO SASH 330020

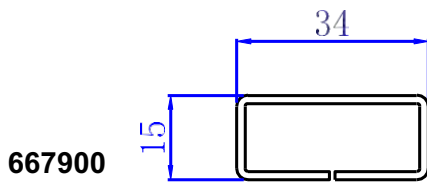
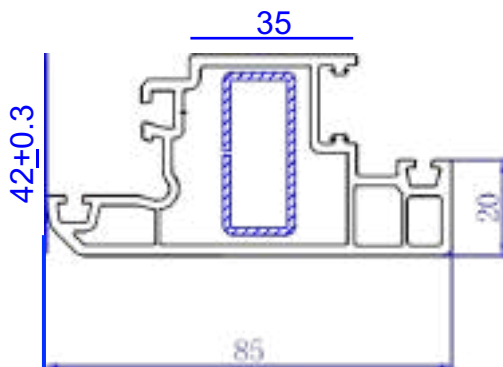

667900

OUTER WINDOW SASH 310300

l: 291580 e: 40.31

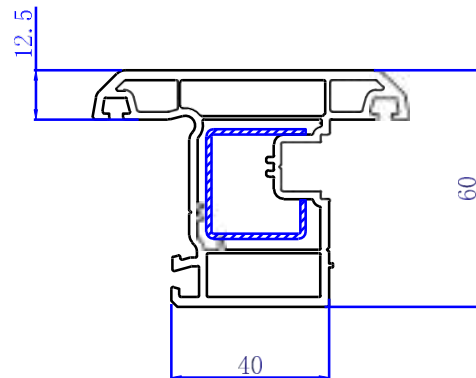

360300
t=1.5 ly=1.740
t=2.0 ly=2.213



GLAZING BEAD 34.5 320400

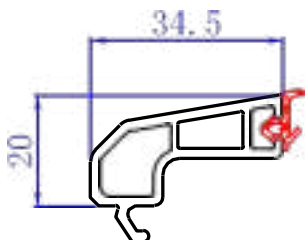

GLAZING BEAD 19.5 320100

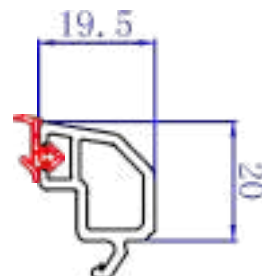

Estd. 1933

DIMEX[®]

German uPVC Windows & Doors System

QUALITY CERTIFICATE

10 YEARS WARRANTY ON WHITE & 25 YEARS ON LAMINATED PROFILES

For _____

DIMEX hereby declares 10 years warranty on its Profiles against all manufacturing and material defects

DIMEX Profiles contain 8 parts of UV repellent Titanium Dioxide

DIMEX Profiles are tested for RHOS & are Lead Free

DIMEX Profiles Outer Wall Thickness is up to 2.3mm

DIMEX Profiles belong to B category of German IFT Classification recommended for 'Hot Climates'

DIMEX Renolit® Laminated profiles are warranted up to 25 years/ Renolit® original warrantees are directly transferred to the customer

DIMEX

**Helping YOU
live safe, live secure.
Since 1933!**

www.dimexindia.com



DIN EN ISO 9001

* All warranties are subject to the guidelines. Is Valid only through DIMEX Authorized Dealers

CERTIFICATE ISSUANCE : Our Quality Certificate is issued to our Fabricators once they become a part of the Dimex India family based on meeting our fabrication and service requirements, thus ensuring sustained quality and client satisfaction standards within our market network.

Estd. 1933



No.....

German uPVC Windows & Doors System

Authorization

we hereby certify that

M/s _____

are DIMEX authorized Fabricator.
They have pledged to deliver
uPVC Windows & Doors made out of
DIMEX Systems, following strictly the
German norms of Fabrication & Installation.



www.dimexindia.com



DIN EN ISO 9001

CERTIFICATE ISSUANCE : Our Authorization Certificate is issued to our Fabricators once they become a part of the Dimex India family based on meeting our sales and service requirements, thus ensuring sustained quality and client satisfaction standards within our market network.

Estd. 1933



German uPVC Windows & Doors System

www.dimexindia.com

HEAD OFFICE

R 4/37 M3M Urbana
Golf Course Ext. Road
Sector-67 Gurgaon,
Haryana-122 002
+919953571811/9910760737
business@dimexindia.com

MANUFACTURING UNIT

DHENU INDUSTIRES LLP
SY # 98
Tulekalan (V)
Ibrahimpnam (M)
R.R. Distt. Telangana
+91 9849312645